

Printed Pages: 04

Subject Code: EME102/ NME102

Paper Id: 140106

Roll No:

--	--	--	--	--	--	--	--	--	--

B.Tech.
(SEM I) THEORY EXAMINATION 2018 – 19
ENGINEERING MECHANICS

Time : 3 Hours

Max. Marks : 100

Note : Attempt **all** the Sections. Assume missing data if any, suitably.

Section-A

1. Attempt *ALL* parts. All parts carry equal marks and up to 75 words . (2*10 =20)

- (a) Define force and it's elements.
- (b) State Lami's theorem.
- (c) State and prove Varignon's theorem.
- (d) Write down the assumptions in truss analysis.
- (e) Discuss term moment of inertia and it's significance.
- (f) Locate centroid of a wire bent in the form of semi circle.
- (g) Differentiate between resultant and relative velocity .
- (h) Define section modulus and polar modulus.
- (i) Define the term strain energy.
- (j) State D'Alembert's principle.

Section-B

Note: Attempt *any three* questions. All questions carry equal marks. (10*3=30)

- (2) A smooth weightless cylinder of radius 600 mm rests on a horizontal plane and is kept from rolling by an inclined string of 1000 mm length. A bar AB of length 1500 mm and weight 1200 N is hinged at A and placed against the cylinder. Determine tension in the string.

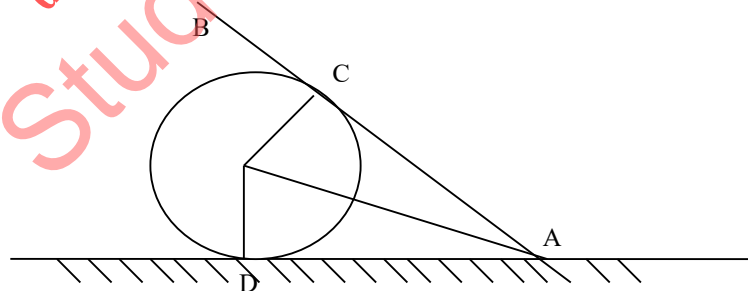

- (3) Draw the SFD and BMD for the given beam. Also find out the position of max BM and point of contraflexure if any.

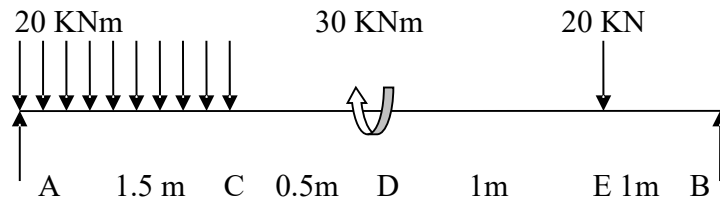

(4) Locate centroid of given plane figure. Also find out MOI about base.

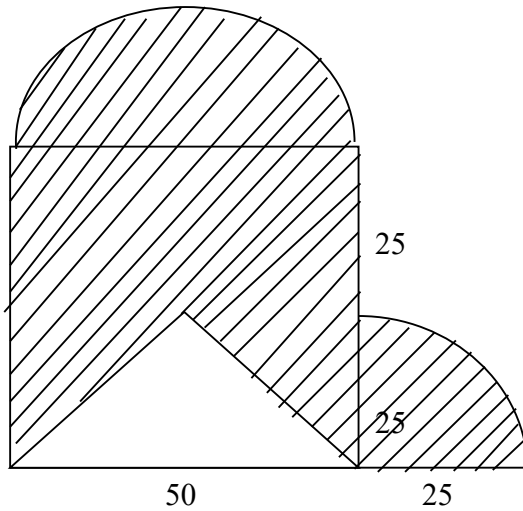

(5) . State and derive Impulse- Momentum equation. (3)

A pulley of weight 400N has a rad of 0.6 m. A block of 600 N is suspended by a tight rope wound round the pulley. Other end being attached to the pulley. Determine acceleration of weight and tension in the rope. (7)

(6) Calculate the minimum diameter of a solid steel shaft which is not allowed to twist not more than 3° in a 6 m length when subjected to a torque of 12 kNm. Also calculate the maximum shearing stress developed. $G = 83 \text{ GPa}$

Section – C

Attempt *All* questions. All questions carry equal marks and up to 500 words. (10*5=50)

7 a). Define terms Angle of limiting friction, Angle of repose, Cone of friction, Laws of dry friction (3)

b). Block A & B connected by a rigid horizontal bar, pinned at either end are placed on inclined plane. The weight of block B is 300N. Find the limiting weight of block A to just start motion of the system. $\mu_a = 0.25, \mu_b = 0.3$ (7)

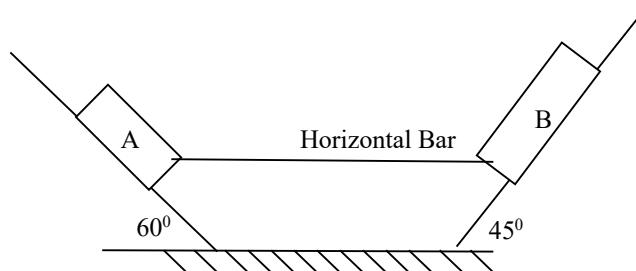

OR

Two cylinders A & B of diameters 60 mm and 30 mm weighing 80 kN and 20 kN respectively are placed in a channel. Find out reactions at all the contact points.

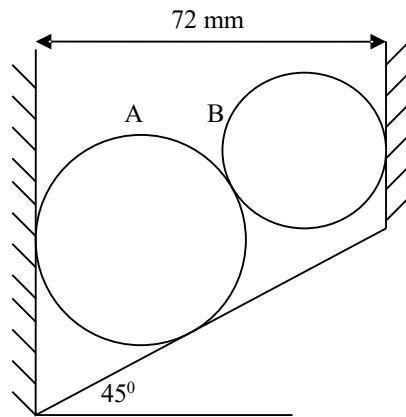

(8) Find out axial forces in all the members of truss. All sides of truss are 5 m. Also find out tension in rope

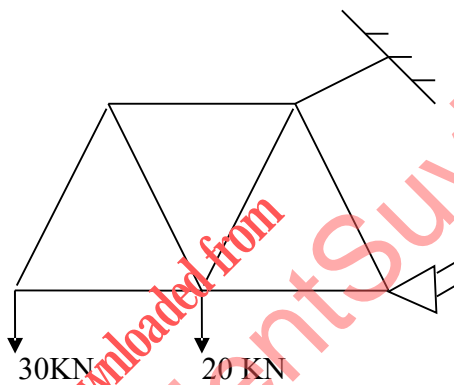

OR

Draw the Shear force & Bending moment diagram for given beam.

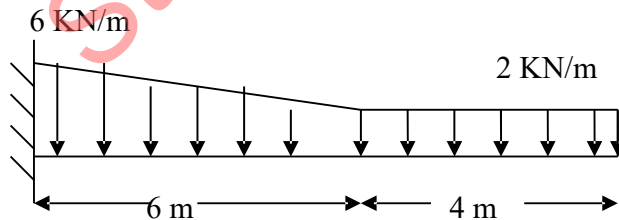

- (9) (a) Derive an expression for mass moment of inertia of solid sphere about its axis. (5)
(b) Find out centroid of a given composite section, where triangle is removed from a semi circle. (5)

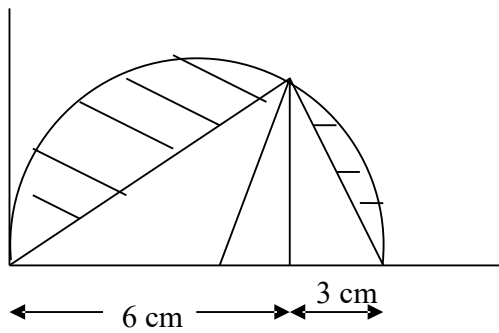

OR

- (a) Define parallel axis and perpendicular axis theorem. (5)
- (b) Derive an expression for mass moment of inertia of a cylinder about its transverse centroidal axis. (5)

10. Attempt any one of the following.

- (a) A sphere, cylinder and hoop is released from the top of an inclined and rolling. What will be the velocity at the end of inclined plane.
- (b) A horizontal bar 1.5 m long and of small cross section rotates about vertical axis through one end. It accelerates uniformly from 1200 rpm to 1500 rpm in an interval of 5 seconds. What is the linear velocity at the beginning and the end of interval. What are the normal and tangential components of acceleration of the mid point of the bar after 5 seconds.

(11). Attempt any two of the following. (5*2=10)

- (a) Draw the Stress – Strain diagram for ductile material mild steel under tension and discuss all the salient points.
- (b) Determine the dimensions of a simply supported rectangular steel beam 6 m long to carry a brick wall 250 mm thick and 3 m high. If the brick weight is 20 KN/m³ and the maximum stress is 800 N/cm². The depth of beam is 1.5 times of its width.
- (c) Find out total elongation of round steel bar of 25 mm diameter subjected to axial loads. $E = 210 \text{ GPa}$

